

# UNION SNELSTART MET BOSCH-SYSTEEM

UNION QUICK START WITH BOSCH-SYSTEM

NL

EN

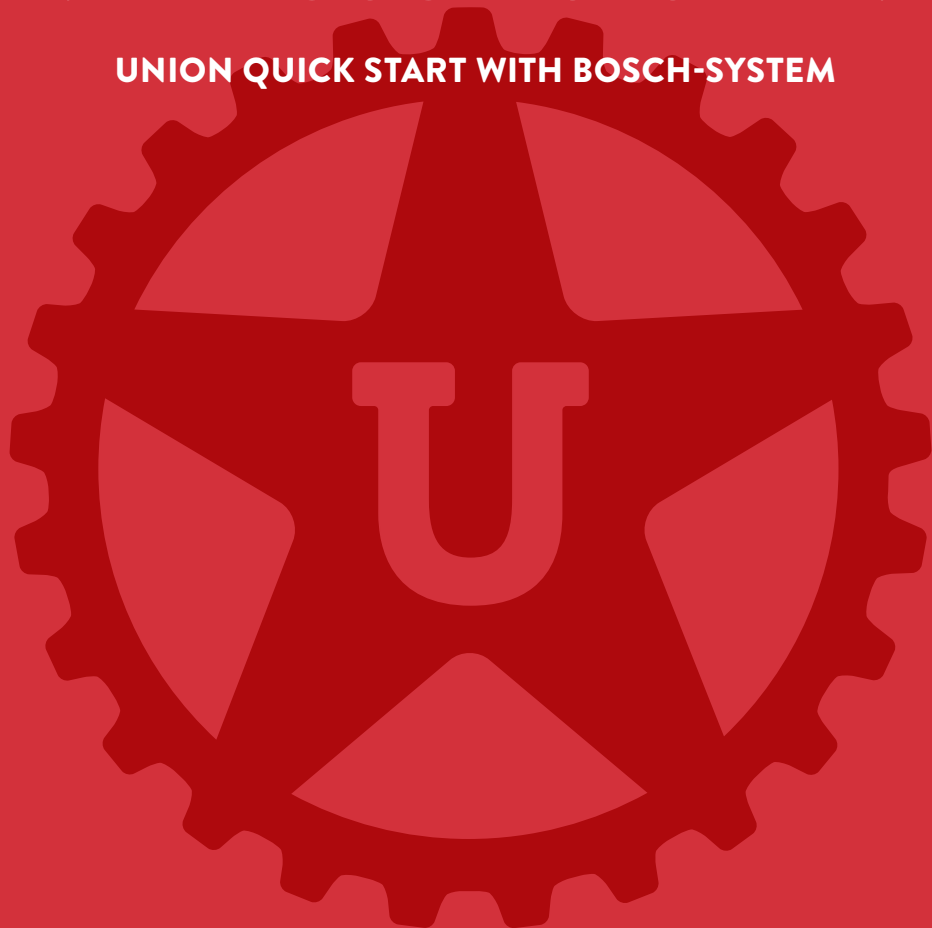

BIKERS FIRST

**UNION**<sup>®</sup>

# CONGRATULATIONS ON YOUR UNION BIKE!

NL

EN

Congratulations on your new Union bike with innovative Bosch system!

Read the quick start guide carefully and if you have any further questions, your Union dealer will be happy to provide you with advice and assistance. All our manuals and warranty conditions can also be found on our website [www.union.nl](http://www.union.nl)

OFF YOU GO, BIKERS FIRST!

# 1. SAFETY

## 1.1 LEGAL REQUIREMENTS

 Like all cycles, the bike must comply with the requirements of the national highway code. The legal requirements set out below are applicable to the bike:

- The motor may only be used to assist pedalling, i.e. it must only “help” when the bike user applies effort to the pedals him or herself. The walk assist function is an exception to this is, it helps you when wheeling the bike.
- The average motor power rating must not exceed 250 W. As speed increases motor power must continue to drop progressively.
- The motor must cut out at (approximately) 25 km/h.

See also the supplied EC Declaration of Conformity.

## 1.2 SAFETY AND WARRANTY

 Read the Safety and Warranty manual for all safety instructions and warranty conditions on our website [www.union.nl](http://www.union.nl).

## 1.3 MAINTENANCE AND REPAIR

 When carrying out settings, as well as maintenance or cleaning jobs, be aware that cables must not be pinched and/or kinked nor must they be damaged by sharp edges. Have all fitting and setting jobs carried out by your Union specialist.

Observe operating and storage temperatures for e-bike components. Protect the motor, display and battery against extreme temperatures (e.g. intense sunlight without adequate ventilation). These components (especially the battery) can be damaged by extreme temperatures.

## 2. BIKE CONFIGURATION

### 2.1 BOSCH BIKE WITH CARRIER BATTERY

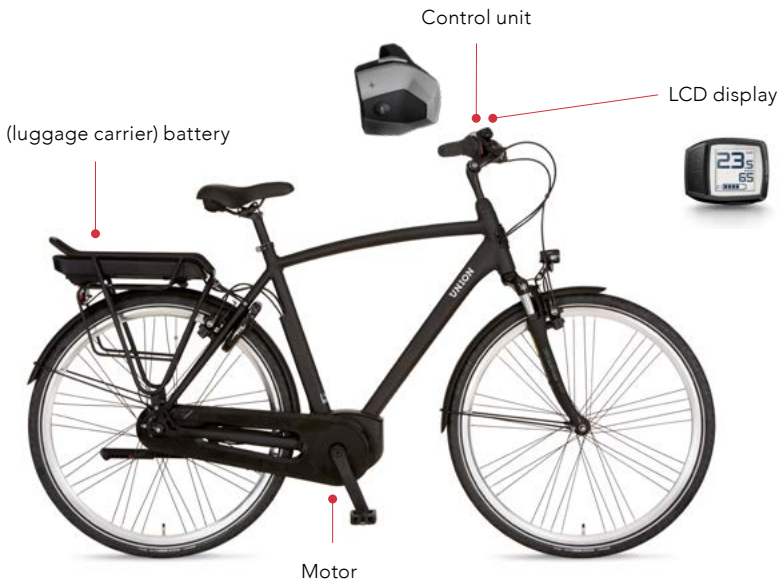

NL

EN

## 3. BOSCH SYSTEM QUICK START

### 3.1 CARRIER BATTERY

1. Check the battery before charging it for the first time or using it with your e-bike. Do this by pressing the -button **A4** to switch on the battery.

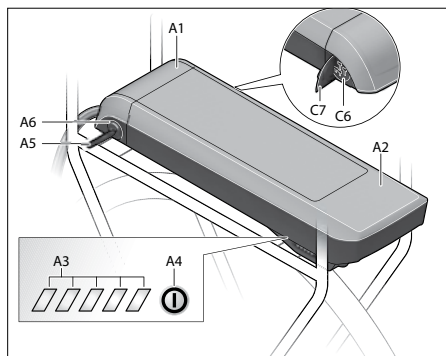

Carrier battery

 If there are no LEDs lit up on charge indicator **A3**, the battery is likely to be damaged. If at least one LED is lit, but not all LEDs on charge indicator **A3** are lit, you will need to charge the battery fully before first use. (Charging temperature: 0 to 40 °C).

When charging the battery you can also remove it and charge it off the bike.

2. Remove protector **C7** from the charging connection.
3. Connect charger plug **C5** to battery **A2**.

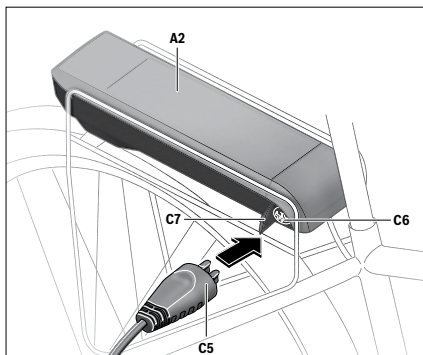





Charging carrier battery on the bike

4. Connect the charger mains plug to a mains socket.
5. Once all the battery LEDs on charge indicator **A3** are lit, the battery is fully charged. Pull charger plug **C5** out of the charging connection and remove the charger mains plug from the mains socket.
6. If you have charged the battery off the bike, you should fit it back under the luggage carrier.

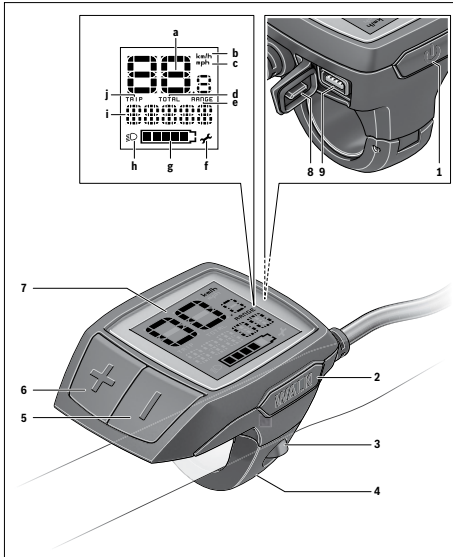
You will find more information about battery life in our comprehensive manual at [www.union.nl](http://www.union.nl).

## 3.2 PURION DISPLAY



1. Activate the electrical system by briefly pressing the -button **1** on the display once or by briefly pressing the -button **A4** on the battery once.
2. Check your battery charge status by checking the LED indicator lights on the battery **A3** or on your display **g**. Each indicator light which is lit represents around 20% of battery capacity.
3. You can select the desired assistance level by pressing the  /  (buttons **5** and **6**) on the display: **ECO**, **TOUR**, **SPORT**, **TURBO** or no assistance (**OFF**).

You will find comprehensive information relating the battery, the motor, the display, the charger, the speed sensor, range, diagnosing faults, remedying faults, maintenance and technical specifications in the comprehensive manual at [www.union.nl](http://www.union.nl)

We wish you a great deal of pleasure using your new bike with the Bosch drive system!

NL

EN

## UNION B.V.

Wilhelminaweg 8  
6951 BP Dieren  
Nederland

 [www.union.nl](http://www.union.nl)

 [facebook.com/union-bikes](https://facebook.com/union-bikes)

 [instagram.com/unionbikes](https://instagram.com/unionbikes)

 [youtube.com/union-bikes](https://youtube.com/union-bikes)